

**RECTANGULAR**

**CIRCULAR**



CHROME

CHROME



WHITE

WHITE



BLACK

BLACK



BRUSHED GOLD

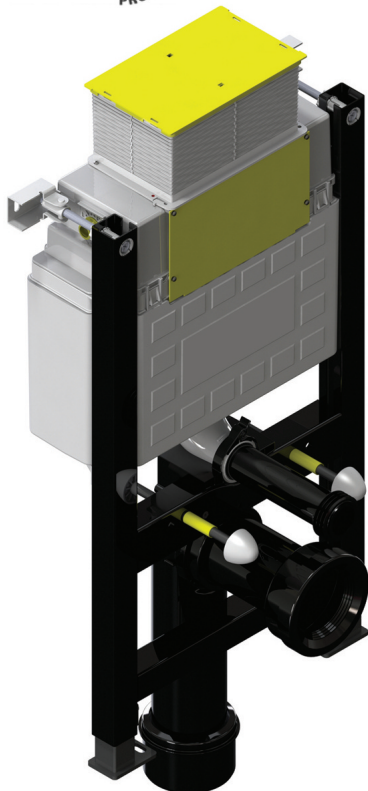

## FRONT/TOP ACCESS FAST FIX FRAME FOR WALL HUNG WC



APPROVED



HEALTHCARE



COMMERCIAL



DOMESTIC



EDUCATION



HOTEL & LEISURE

### PRODUCT INFORMATION

Fastfix frame including pan connectors, cistern with front and top access dual flush compact cistern and rectangular fascia plate

T064113P43 - with CHROME rectangular plate

T064113P44 - with WHITE rectangular plate

T064113P45 - with BLACK rectangular plate

T064113P47 - with CHROME circular plate

T064113P48 - with WHITE circular plate

T064113P49 - with BLACK circular plate

T064113P50 - with Brushed GOLD circular Plate

### FLUSH VOLUME

6/4 or 4/2.6 Litres

### MATERIAL

Steel

### COLOUR/FINISH

Chrome Fascia Plate

### MANUFACTURER

Wilco

### FIXING

Secure to floor and upright structures using fixings provided

### STANDARDS

EN 14055

### APPROVALS

WRAS Approval pending

### PRODUCT DIMENSIONS

W420 x H780 - 800 x D155-185mm

### WEIGHT

14.56KG

### ADDITIONAL INFORMATION

Suitable for use with stud walls where adequate grounds are provided.  
Load capacity 400KG.

